

Construction

These directly controlled 2/2-way solenoid valves have a completely plastic encapsulated DC solenoid which drives the armature. The displacement of the armature takes place within a bellows made of PTFE backed by a safety diaphragm which provides additional sealing protection. The valve seat is directly mounted to the PTFE bellows. The valve body can be supplied either for straight through flow or with inlet and outlet at right angles. The electrical connection is made via a plug complying with DIN EN 175301-803 Form A. It has a rectifier for use with an AC supply.

Features

- Suitable for inert and corrosive* liquid and gaseous media
- Corrosion-resistant, therefore suitable for water treatment plants, washing and cleaning installations, the food and foodstuffs industries, the chemical industry, electroplating, titration equipment, for the photographic industry and for laboratory, analytical and medical apparatus.
- UL approval available as an option

Advantages

- Easy to clean; the valve can be dismantled without tools by unscrewing the union nut
- The solenoid can be replaced without removing the valve body from the pipeline
- Hermetic separation between medium and actuator

* see information on working medium on page 2



GEMÜ 52



GEMÜ 102



GEMÜ 202

Sectional drawing GEMÜ 202

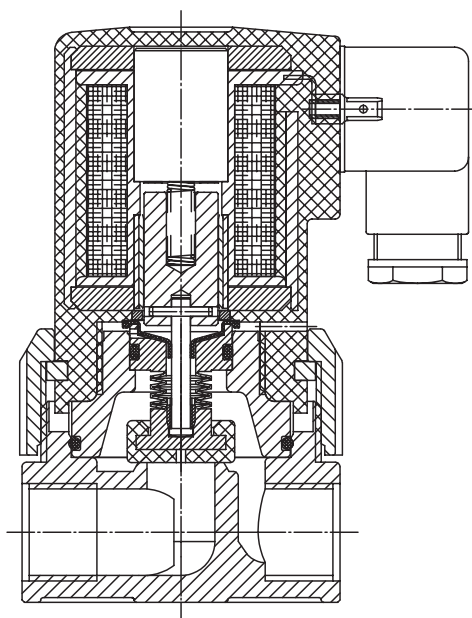

Technical data

Working medium

Corrosive, inert, gaseous and liquid media which have no negative impact on the physical and chemical properties of the body and seal material.

Max. perm. temperature of working medium:
 PVC-U version (code 1) 60° C
 PVDF version (code 20) 100° C

Ambient conditions

Max. permissible ambient temperature 40°C

Protection class to EN 60529

IP 65

Cable gland

PG 11

Rating

100% continuously rated

Approvals

UL approval Y10Z2

Electrical data

Power supply*

Supply voltage (-10%/+6%)	Mains frequency (± 1%)
24 V AC	50/60 Hz
120 V AC	50/60 Hz
230 V AC	50/60 Hz
12 V DC	-
24 V DC	-

Electrical power consumption

AC voltage		Pull in / hold in
Type 52	DN 2 - 6	6.0 VA
Type 102	DN 6 - 10	9.0 VA
Type 202	DN 10 - 15	14.0 VA
DC voltage		
Type 52	DN 2 - 6	6.0 W
Type 102	DN 6 - 10	9.0 W
Type 202	DN 10 - 15	14.0 W

*permissible voltage tolerance to VDE 0580

Pressure / temperature correlation for plastic

Temperature in °C (plastic body)	-20	-10	±0	5	10	20	25	30	40	50	60	70	80	90	100
Valve body material	permissible operating pressure in bar														
PVC-U Code 1	-	-	-	6.0	6.0	6.0	6.0	4.8	3.6	2.1	0.9	-	-	-	-
PVDF Code 20	6.0	6.0	6.0	6.0	6.0	6.0	6.0	5.4	4.8	4.3	3.8	3.2	2.8	2.2	1.0

Data for extended temperature ranges on request. Please note that the ambient temperature and medium temperature generate a combined temperature at the valve body which must not exceed the above values.

Type	Nominal size* [mm]	Operating pressure [bar]	K _v value [m ³ /h]	Weight [kg]
52	2	0 - 6	0.15	0.21
52	4	0 - 3	0.30	0.21
52	6	0 - 1.5	0.60	0.21
102	6	0 - 4	0.75	0.48
102	8	0 - 2	0.90	0.58
102	10	0 - 1	1.10	0.48
202	10	0 - 2	1.70	1.2
202	15	0 - 1	2.30	1.2

*Nominal size corresponds to valve seat diameter.

All pressures are given as gauge values.

Notes

Installation note

Caution: DC solenoids are designed for unsmoothed voltages, e.g. as obtained from a bridge rectifier.

Wiring note:

Special wiring on request. When using electronic switches and additional wiring avoid inadmissible residual currents by proper design.

Order data

Body configuration	Code
Straight through body	D
Angled body (outlet downwards)	E

Connection	Code
Threaded sockets DIN ISO 228	1
Solvent cement sockets - DIN (only with PVC-U)	2

Valve body material	Code
PVC-U, grey	1
PVDF	20

Seal material	Code
FPM	4
PTFE	5
EPDM	14

Control function	Code
Normally closed	1

Supply voltage	Code
12V	12
24V	24
120V	230
230V	230
240V (only with UL approval)	240

Mains frequency	Code
50/60 Hz	50/60
-	DC

Approval	Code
without	-
UL approval	U

Voltage / Frequency availability		
Standard		
AC	24V	50/60 Hz
	120V	50/60 Hz
	230V	50/60 Hz
DC	12V	DC
	24V	DC
		DC
with UL approval		
AC	24V	50/60 Hz
	230V	50/60 Hz
DC	12V	DC
	24V	DC
Other voltages on request.		

Order example	102	10	D	2	1	5	1	230	50/60	-
Type	102									
Nominal size		10								
Body configuration (code)			D							
Connection (code)				2						
Valve body material (code)					1					
Seal material (code)						5				
Control function (code)							1			
Supply voltage (code)								230		
Mains frequency (code)									50/60	
Approval (code)										-

Order information: Suitable plug acc. to DIN EN 175301-803 form A, loose plug: type GEMÜ 1220/1221

Actuator dimensions - GEMÜ 52, 102, 202 [mm]

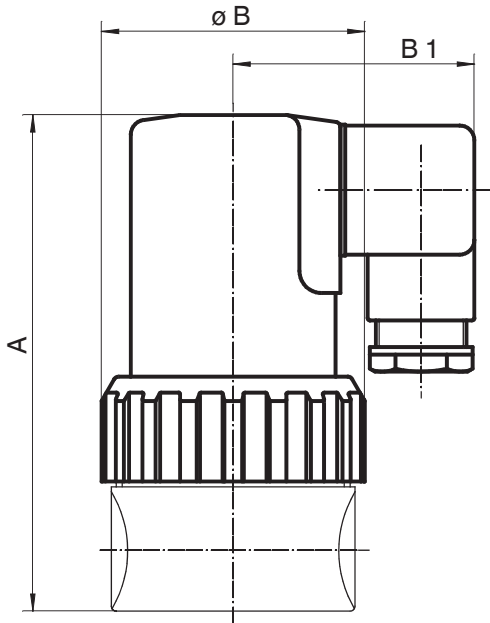

Type	A		$\varnothing B$	B1	
Body configuration	D	E		AC	DC
52	83	91	38	52	45
102	101	109	54	50	50
202	123	123	68	67	60

Body configuration: D = straight through body, E = angled body

Body dimensions

Threaded sockets, connection code 1 [mm] Valve body material: PVC-U (code 1), PVDF (code 20)

Type	DN	G	Straight through body (code D) H 1	Angled body (code E) H 1	t	L
52	2	G 1/4	11	19	11	38
	4	G 1/4	11	19	11	38
	6	G 1/4	11	19	11	38
102	6	G 1/4	13	21	12	50
	8	G 1/4	13	21	12	50
	10	G 3/8	13	21	12	50
202	10	G 3/8	15	15	16	68
	15	G 1/2	15	15	16	68

Straight through body (code D)

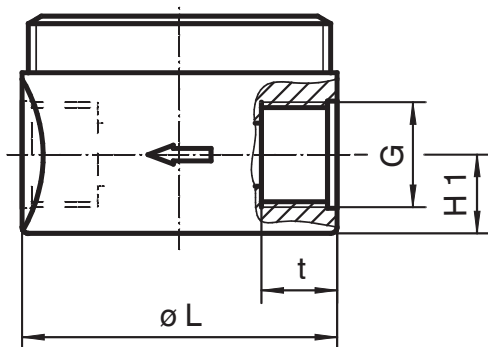

Angled body (code E)

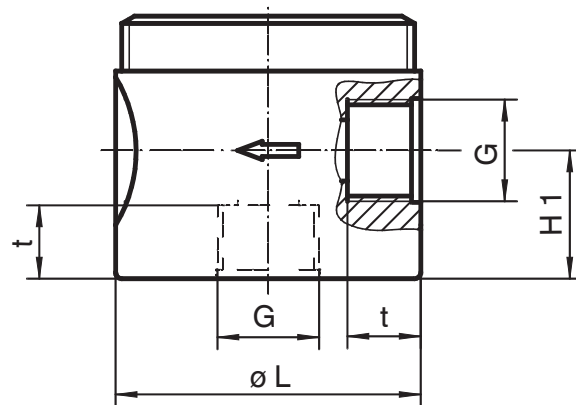

Body dimensions

Solvent cement sockets, connection code 2 [mm] Valve body material: PVC-U (code 1)						
Type	DN	$\varnothing d$	Straight through body (code D)	Angled body (code E)	t	L
			H 1	H 1		
52	2	10	11	19	11	38
	4	10	11	19	11	38
	6	10	11	19	11	38
102	6	12	13	21	12	50
	8	12	13	21	12	50
	10	16	13	21	12	50
202	10	16	15	15	16	68
	15	20	15	15	16	68

Straight through body (code D)

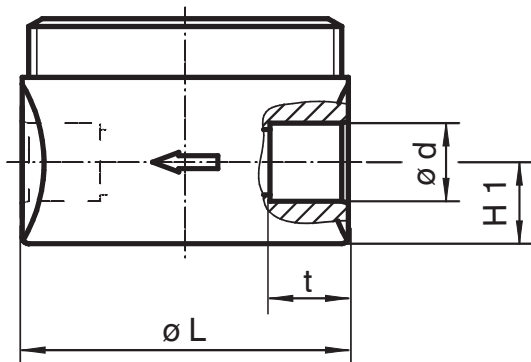

Angled body (code E)

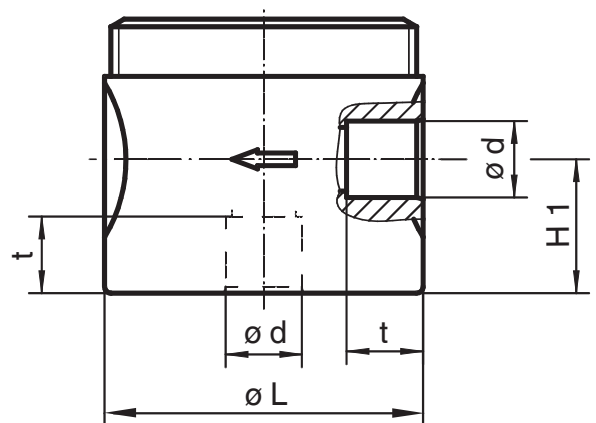

Mounting dimensions [mm]
GEMÜ 52, 102, 202

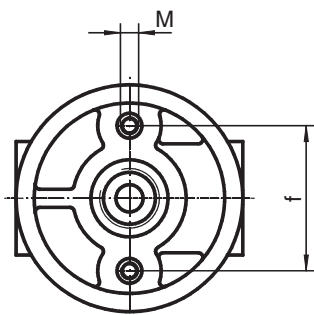

Type	f	M
52	22.5	M3 - 5 mm deep
102	32	M4 - 7 mm deep
202	40	M5 - 9 mm deep

Connection diagram for plug
form A (DIN EN 175301-803)

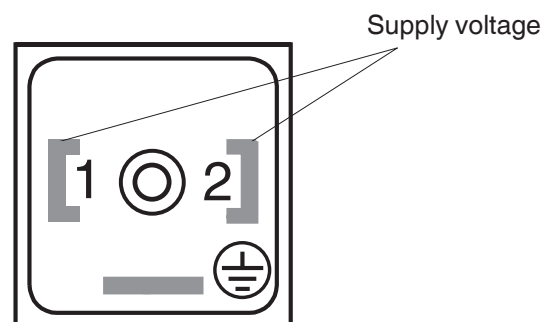

The GEMÜ 1220 plug (without light) or GEMÜ 1221 (with light) is available as a spare part.

Overview of valve bodies for GEMÜ 52, 102, 202

Material code		PVC-U (code 1)		PVDF (code 20)
Connection code		1	2	1
Type	DN			
52	2	X	X	X
	4	X	X	X
	6	X	X	X
102	6	X	X	X
	8	X	X	X
	10	X	X	X
202	10	X	X	X
	15	X	X	X

Other GEMÜ plastic solenoid valves



GEMÜ 105
DN 6 u. 10, (0 - 6 bar)



GEMÜ 205
DN 10 - 50, (0 - 6 bar)



GEMÜ 225
DN 15 - 50, (0 - 6 bar)

Other GEMÜ brass or stainless steel solenoid valves

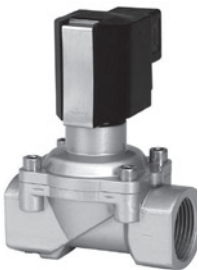

GEMÜ 8253
DN 8 - 50, (0 - 10 bar)



GEMÜ 8257
DN 10, (0 - 10 bar)

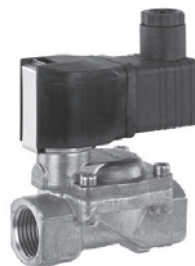

GEMÜ 8258
DN 8 - 50, (0,1 - 16 bar)



GEMÜ 8259
DN 2 - 5, (0 - 20 bar)

For other solenoid valves, accessories and other products, please see our Product Range catalogue and Price List.
Contact GEMÜ.



GEMÜ® VALVES, MEASUREMENT
AND CONTROL SYSTEMS

