

VT67EB SERIES DOUBLE VANE PUMPS

High performance pumps for industrial use,
max pressure up to 320 bar.



HIGH PERFORMANCE VANE PUMP VT67EB

VT67EB - 066 - B08 1 R 00 - A 1 M1 -

Series- SAE C 2 bolts
Mounting flange J744c

Cam ring for "P1"

Volumetric displacement cm³/rev (in³/rev)

042 = 132.3 (8.07)	062 = 196.7 (12.00)
045 = 142.4 (8.69)	066 = 213.3 (13.02)
050 = 158.5 (9.67)	072 = 227.1 (13.86)
052 = 164.8 (10.06)	085 = 269.8 (16.46)
057 = 180.7 (11.02)	

Cam ring for "P2"

Volumetric displacement cm³/rev (in³/rev)

B02 = 5.7 (0.35)	B09 = 28.0 (1.71)
B03 = 9.8 (0.60)	B10 = 31.8 (1.94)
B04 = 12.8 (0.78)	B11 = 34.9 (2.13)
B05 = 15.9 (0.97)	B12 = 40.9 (2.50)
B06 = 19.8 (1.21)	B14 = 45.1 (2.75)
B07 = 22.5 (1.37)	B15 = 50.0 (3.05)
B08 = 24.9 (1.52)	

Type of shaft

- 1 - keyed (SAE CC)
- 2 - keyed (no SAE)
- 3 - splined (SAE C)
- 4 - splined (SAE CC)

Modifications

Mounting W/connection variables

P1=11" P2=3/4" S=31"	
UNC	METRIC
01	M1

Seal class

- 1 - S1 (for mineral oil)
- 4 - S4 (for fire resistant fluids)
- 5 - S5 (for mineral oil and fire resistant fluids)

Design letter

Porting combination (see page BM-1-5)

00 - standard

Direction of rotation (view on shaft end)

- R - clockwise
- L - counter-clockwise



INTERNAL LEAKAGE (TYPICAL)

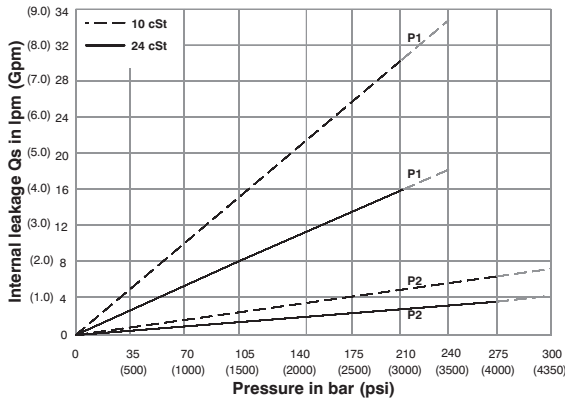

Do not operate pump more than 5 seconds at any speed or viscosity if internal leakage is more than 50% of theoretical flow.
Total leakage is the sum of each section loss at its operating conditions.

NOISE LEVEL (TYPICAL)
VT67EB- 050-B03

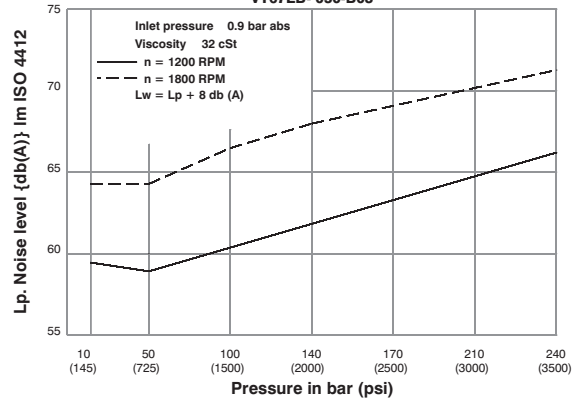

Double pump noise level is given with each section discharging at the pressure noted on the curve.

HYDROMECHANICAL POWER LOSS (TYPICAL)

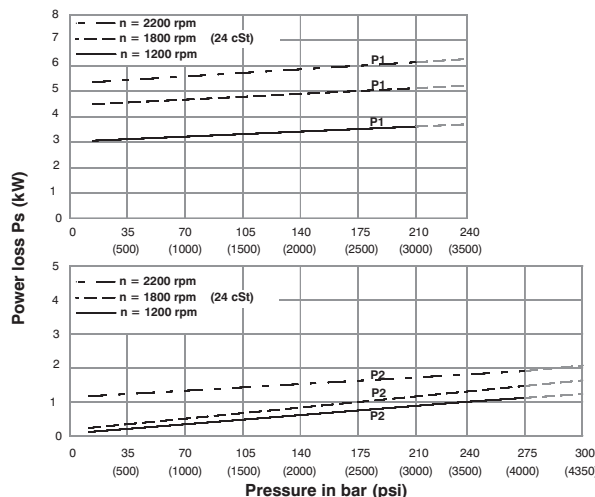

Total hydromechanical power loss is the sum of each section at its operating conditions.

PERMISSIBLE RADIAL LOAD

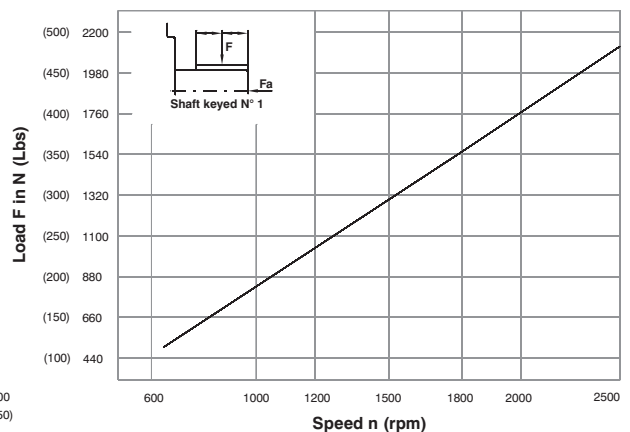

Maximum permissible axial load Fa = 2000 N (449 Lbs)

HIGH PERFORMANCE VANE PUMP VT67EB

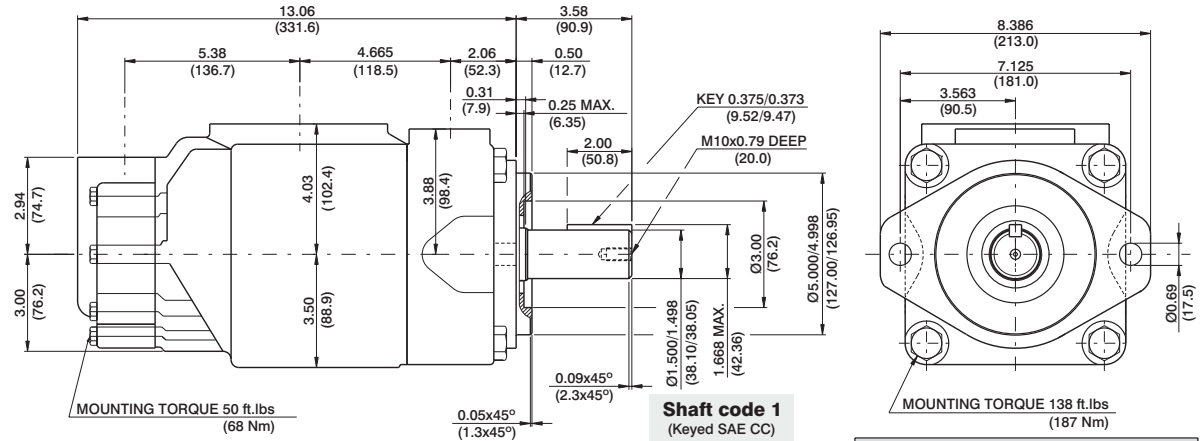
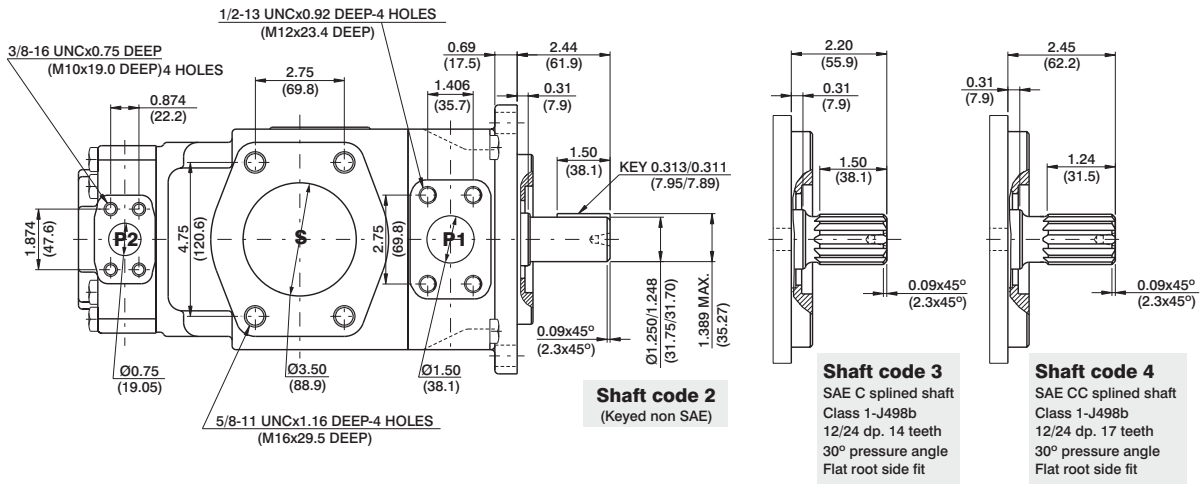

Shaft torque limits in ³ /rev x psi (ml/rev x bar)	
Shaft	Vp x p max. (P1+P2)
1	64044 (72306)
2	30638 (34590)
3	54207 (61200)
4	67582 (76376)

OPERATING CHARACTERISTICS - TYPICAL (24 cST) (Input power p (KW) for one cartridge only)

Pressure port	Series	Volumetric Displacement Vp		Flow q & n = 1800 rpm								Input power p & n = 1800 rpm			
		cm ³ /rev		p = 0 bar (0 psi)		p = 140 bar (2000 psi)		p = 240 bar (3500 psi)		p = 7 bar (100 psi)		p = 140 bar (2000 psi)		p = 300 bar (4350 psi)	
		in ³ /rev	cm ³ /rev	gpm	lpm	gpm	lpm	gpm	lpm	hp	kw	hp	kw	hp	kw
P1	042	8.07	132.3	62.92	237.8	60.37	228.2	58.52	221.2	8.09	6.03	78.44	58.49	133.80	99.78
	045	8.69	142.4	67.72	256.0	65.17	246.3	63.32	239.4	8.37	6.24	84.04	62.67	143.60	107.08
	050	9.67	158.5	75.38	285.0	72.83	275.3	70.98	268.3	8.82	6.58	92.97	69.30	159.24	118.7
	052	10.06	164.8	78.37	296.2	75.82	286.3	73.97	279.6	8.99	6.70	96.47	71.94	165.36	121.31
	057	11.02	180.7	71.70	325.3	69.07	261.1	80.63	304.8	9.40	7.00	114.30	85.14	172.10	128.30
	062	12.00	196.7	93.54	353.6	90.99	344.0	89.14	337.0	9.88	7.36	114.17	84.00	196.34	146.41
	066	13.02	213.3	101.44	383.4	98.89	373.8	97.04	366.8	10.34	7.71	123.38	92.01	212.46	158.43
	072	13.86	227.1	108.00	408.2	105.45	400.0	103.60	391.6	10.72	8.00	131.04	97.72	225.86	168.42
	085 ¹⁾	16.40	268.7	127.08	483.0	126.13 ²⁾	476.7 ²⁾	--	--	11.66	8.70	87.56 ²⁾	65.30 ²⁾	--	--
P2	B02	0.35	5.7	2.76	10.4	2.33	8.8	1.80	6.8	0.74	0.55	4.02	2.99	8.10	6.40
	B03	0.60	9.8	4.66	17.6	4.23	15.9	3.70	14.0	0.85	0.63	6.24	4.65	12.93	10.25
	B04	0.78	12.8	6.09	23.0	5.66	21.4	5.13	19.4	0.94	0.70	7.90	5.89	16.55	13.13
	B05	0.97	15.9	7.56	28.6	7.13	26.9	6.60	25.0	1.02	0.76	9.62	7.17	20.29	16.12
	B06	1.21	19.8	9.42	35.6	8.99	33.9	8.46	32.0	1.13	0.84	11.79	8.79	25.00	19.88
	B07	1.37	22.5	10.70	40.4	10.27	38.8	9.74	36.8	1.20	0.89	13.29	9.91	28.26	22.47
	B08	1.52	24.9	11.84	44.7	11.41	43.1	10.88	41.1	1.27	0.94	14.62	10.90	31.15	24.78
	B09	1.71	28.0	13.31	50.3	12.87	48.6	12.35	47.0	1.36	1.01	16.35	12.19	34.92	27.77
	B10	1.94	31.8	15.12	57.2	14.69	55.5	14.16	53.5	1.46	1.11	18.45	13.75	39.48	31.42
	B11	2.13	34.9	16.64	62.9	16.19	61.2	15.68	59.3	1.55	1.15	20.17	15.04	43.22	32.22
	B12	2.50	40.9	19.50	73.7	19.07	72.1	18.54	70.1	1.72	1.28	23.55	17.56	50.58	37.71
	B14	2.75	45.1	21.40	80.8	20.95	79.2	20.44	77.0	1.83	1.36	25.80	19.23	55.48	41.37
	B15	3.05	50.0	23.78	89.8	23.35	88.3	22.88 ³⁾	86.5 ³⁾	1.97	1.47	28.55	21.28	57.35 ³⁾	42.76 ³⁾

1) 085 = 2000 RPM max. 2) 085 = 75 bar (1087 psi) cont. 085 = 90 bar (1300 psi) max. int. 3) B15 = 280 bar (4060 psi) max. int.