

## VT6CC SERIES DOUBLE VANE PUMPS

High performance pumps for industrial use,  
max pressure up to 275 bar.



# HIGH PERFORMANCE VANE PUMP VT6CC

Series **VT6CC W - 022 - 008 - 1 R 00 - C 1 - 00 \***

Use for severe duty shaft only

Cam ring for "P1" & "P2"

Volumetric displacement cm<sup>3</sup>/rev (in<sup>3</sup>/rev)

*003/B03/Y03 = 10.8 (0.66)	015/B15/Y15 = 50.5 (3.08)
005/B05/Y05 = 17.2 (1.05)	017/B17/Y17 = 58.3 (3.56)
006/B06/Y06 = 21.3 (1.30)	020/B20/Y20 = 63.8 (3.89)
008/B08/Y08 = 26.4 (1.61)	022/B22/Y22 = 70.3 (4.29)
010/B10/Y10 = 34.1 (2.08)	025/B25/Y25 = 79.3 (4.84)
012/B12/Y12 = 37.1 (2.26)	028/B28/Y28 = 88.8 (5.42)
014/B14/Y14 = 46.0 (2.81)	031/B31/Y31 = 100.0 (6.10)

\*'0' - Uni-directional 'B' - Bi-directional 'Y' - Bi-directional for cold start

Type of shaft

- 1- keyed (no SAE)
- 3- splined (SAE BB)
- 5- splined (SAE B)

W version

- 2- keyed (SAE BB)
- S-splined (DIN 5462)

Modifications

Mounting W/connection variables

P2 code	P1=1" - S=3"		P1=1" - S=21" <sup>2)</sup>	
	1"	3/4" <sup>1)</sup>	1"	3/4" <sup>1)</sup>
Unc	00	01	10	11
Metric	0M	W0	1M	W1

1) for 46 ml/rev max.

2) for 126 ml/rev max.

The large cartridge must be always mounted in the front.

Seal class

- 1 - S1 (for mineral oil)
- 4 - S4 (for fire resistant fluids)
- 5 - S5 (for mineral oil and fire resistant fluids)

Design letter

Porting combination (see page BM-1-5)

00 - standard

Direction of rotation (view on shaft end)

- R - clockwise
- L - counter-clockwise

## INTERNAL LEAKAGE (TYPICAL)

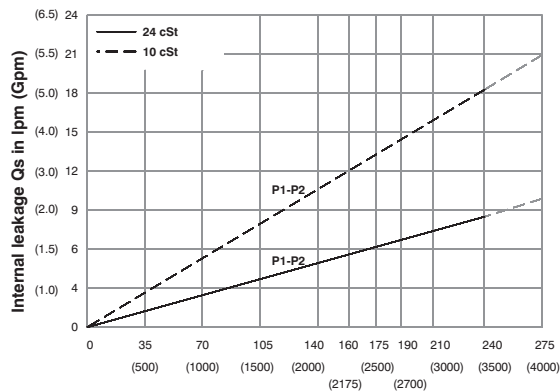

Pressure in bar (psi)

Do not operate pump more than 5 seconds at any speed or viscosity if internal leakage is more than 50% of theoretical flow. Total leakage is the sum of each section loss at its operating conditions.

## NOISE LEVEL (TYPICAL)

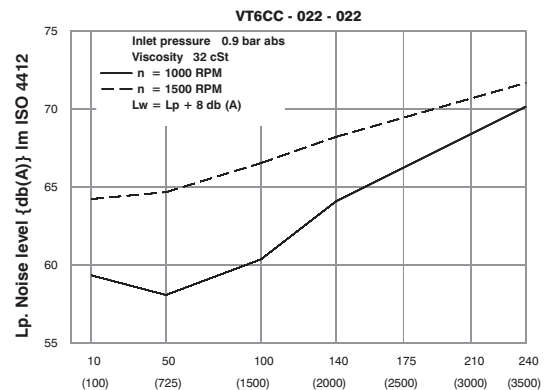

Pressure in bar (psi)

Double pump noise level is given with each section discharging at the pressure noted on the curve.

## HYDROMECHANICAL POWER LOSS (TYPICAL)

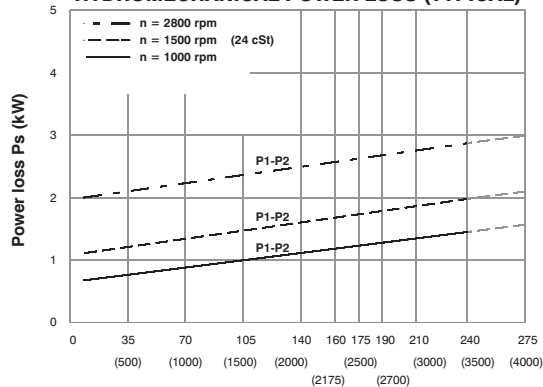

Pressure in bar (psi)

Total hydromechanical power loss is the sum of each section at its operating conditions.

## PERMISSIBLE RADIAL LOAD

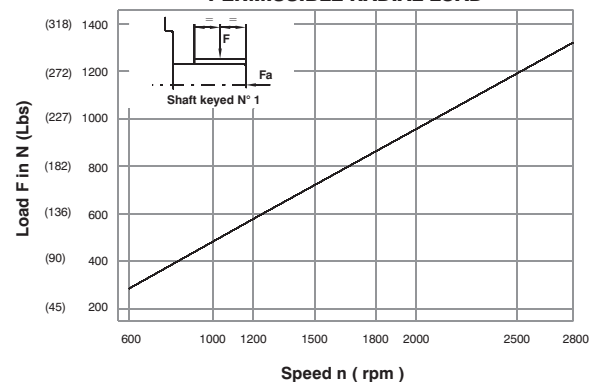

Maximum axial load permissible  $F_a = 800 \text{ N (180 Lbs)}$



# HIGH PERFORMANCE VANE PUMP VT6CC

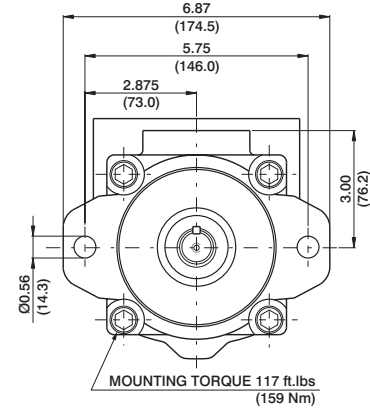
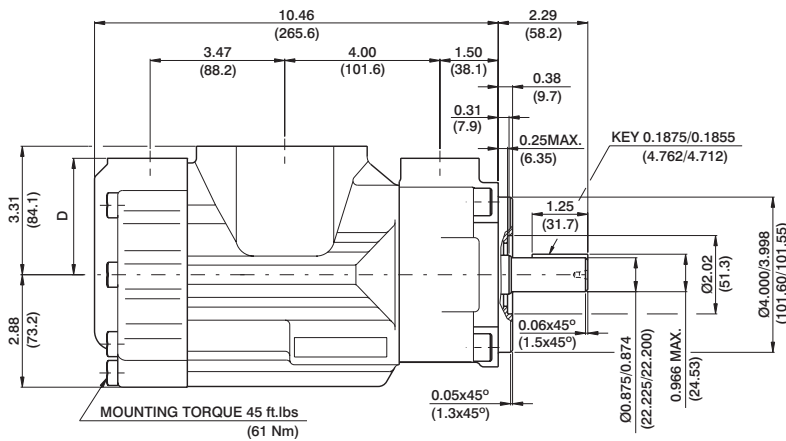
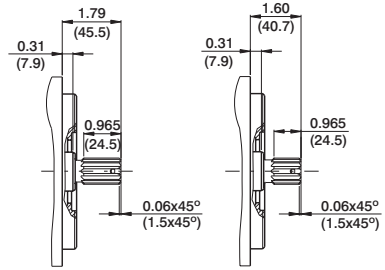
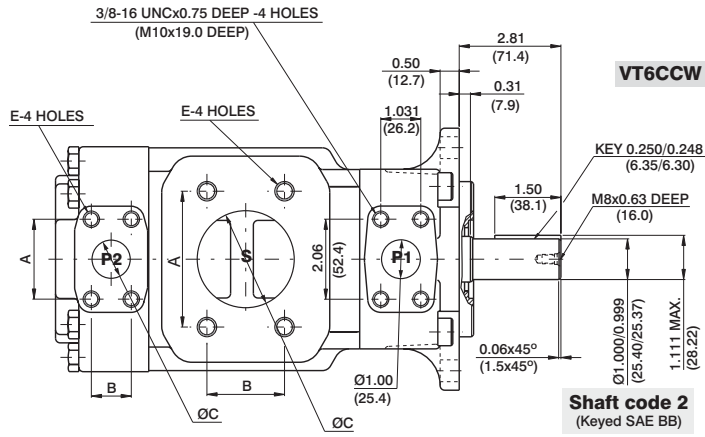

Shaft torque limits in <sup>3</sup> /rev x psi(ml/rev x bar)	
Shaft	Vp x p max. (P1+P2)
1	12666 (14300)
2	18972 (21420)
3	28937 (32670)
5	18246 (20600)

PORT	A	B	C	D	E
S	4.19 (106.4)	2.44 (61.9)	3.00 (76.2)		5/8-11UNCx1.12 DEEP (M16x28.4 DEEP)
S	3.50 (88.9)	2.00 (50.8)	2.50 (63.5)		1/2-13UNCx0.94 DEEP (M12x24.0 DEEP)
P2	1.874 (47.6)	0.874 (22.2)	0.75 (19.0)	3.00 (76.2)	3/8-16UNCx0.75 DEEP (M10x19.0 DEEP)
P2	2.06 (52.4)	1.03 (26.2)	1.00 (25.4)	2.94 (74.7)	

## OPERATING CHARACTERISTICS - TYPICAL (24 cST) (Input power p (KW) for one cartridge only)

Pressure port	Series	Volumetric Displacement Vp		Flow q & n = 1500 rpm						Input power p & n = 1500 rpm					
		p = 0 bar (0 psi)		p = 140 bar (2000 psi)		p = 240 bar (3500 psi)		p = 7 bar (100 psi)		p = 140 bar (2000 psi)		p = 240 bar (3500 psi)			
		in <sup>3</sup> /rev	cm <sup>3</sup> /rev	gpm	lpm	gpm	lpm	gpm	lpm	hp	kw	hp	kw	hp	kw
P1 & P2	003	0.66	10.8	4.29	16.2	2.96	11.2	2.04	7.7	1.74	1.3	7.11	5.3	11.22	8.4
	005	1.05	17.2	6.83	25.8	5.50	20.8	4.57	17.3	1.88	1.4	10.06	7.5	16.36	12.2
	006	1.30	21.3	8.44	31.9	7.11	26.9	6.19	23.4	2.01	1.5	11.94	8.9	19.71	14.7
	008	1.61	26.4	10.48	39.6	9.15	34.6	8.22	31.1	2.15	1.6	14.35	10.7	22.93	17.7
	010	2.08	34.1	13.52	51.1	12.19	46.1	11.26	42.6	2.28	1.7	18.64	13.4	29.90	22.3
	012	2.26	37.1	14.71	55.6	13.36	50.6	12.46	47.1	2.28	1.7	19.31	14.4	32.32	24.1
	014	2.81	46.0	18.25	69.0	16.93	64.0	16.00	60.5	2.55	1.9	23.60	17.6	39.56	29.5
	015	3.08	50.5	20.00	75.6	18.73	73.2	19.02	67.5	2.68	2.0	25.61	19.1	42.91	32.0
	017	3.56	58.3	23.12	87.4	21.79	82.4	20.87	78.9	2.82	2.1	29.37	21.9	49.48	36.9
	020	3.89	63.8	25.32	95.7	23.99	90.7	23.07	87.2	2.95	2.2	31.92	23.8	53.91	40.2
	022	4.29	70.3	27.88	105.4	26.56	100.4	25.63	96.9	3.08	2.3	35.00	26.1	59.14	44.1
	025 <sup>1)</sup>	4.84	79.3	31.46	118.9	30.13	113.9	29.21	110.4	3.35	2.5	39.16	29.2	66.38	49.5
	028 <sup>1)</sup>	5.42	88.8	35.24	133.2	33.92	128.2	33.28 <sup>2)</sup>	125.8 <sup>2)</sup>	3.75	2.8	43.85	32.7	65.04 <sup>2)</sup>	48.5 <sup>2)</sup>
	031 <sup>1)</sup>	6.10	100.0	39.68	150.0	38.35	145.0	37.72 <sup>2)</sup>	142.6 <sup>2)</sup>	3.75	2.8	48.95	36.5	72.95 <sup>2)</sup>	54.4 <sup>2)</sup>

1) 025-028-031 = 2500 RPM. max.    2) 028-031 = 210 bar (3000 psi) max. int.