

## VT6CCZ SERIES DOUBLE VANE PUMPS

High performance pumps for industrial use,  
max pressure up to 275 bar.



# HIGH PERFORMANCE VANE PUMP VT6CCZ

**VT6CCZ \* - B22 - B08 - X R 00 - A 1 - 00 \***

**Series - SAE B 2 bolts**  
Mounting flange J744 c

One letter can be added to specify special parts in series

**Cam ring for "P1" & "P2"**  
Volumetric displacement cm<sup>3</sup>/rev (in<sup>3</sup>/rev)

*B03/R03 = 10.8 (0.66)	B15/R15 = 50.5 (3.08)
B05/R05 = 17.2 (1.05)	B17/R17 = 58.3 (3.56)
B06/R06 = 21.3 (1.30)	B20/R20 = 63.8 (3.89)
B08/R08 = 26.4 (1.61)	B22/R22 = 70.3 (4.29)
B10/R10 = 34.1 (2.08)	B25/R25 = 79.3 (4.84)
B12/R12 = 37.1 (2.26)	B28/R28 = 88.8 (5.42)
B14/R14 = 46.0 (2.81)	B31/R31 = 100.0 (6.10)

\*B' - for Mobile  
'R' - for Mobile - spring assisted

**Type of shaft**

X - keyed  
W - keyed  
V - keyed  
S - Splined (DIN 5462)

**Direction of rotation (view on shaft end)**

R - clockwise  
L - counter-clockwise

**Modification**

**Mounting W/connection variables**

	P1=1". S=3"		P1=1". S=21" <sup>2)</sup>	
P2	1"	3/4" <sup>1)</sup>	1"	3/4" <sup>1)</sup>
code	00	01	10	11
	Unc	OM	1M	W1
	Metric	WO	1M	W1

1) for 46 ml/rev max.  
2) for 126 ml/rev max.  
The large cartridge must be always mounted in the front.

**Seal class**

1 - S1 (for mineral oil)  
4 - S4 (for fire resistant fluids)  
5 - S5 (for mineral oil and fire resistant fluids)

**Design letter**

**Porting combination (see page BM-1-5)**

00 - standard



### INTERNAL LEAKAGE (TYPICAL)

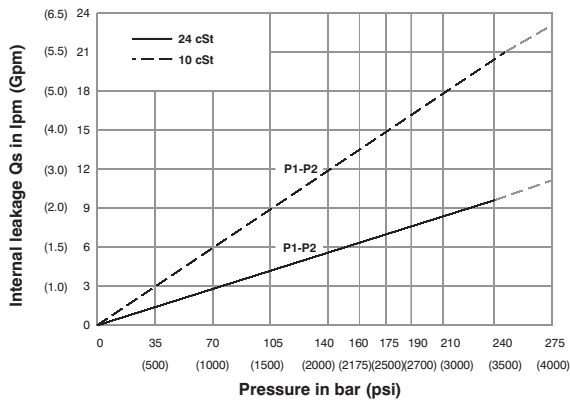

Do not operate pump more than 5 seconds at any speed or viscosity if internal leakage is more than 50% of theoretical flow. Total leakage is the sum of each section loss at its operating conditions.

### NOISE LEVEL (TYPICAL)

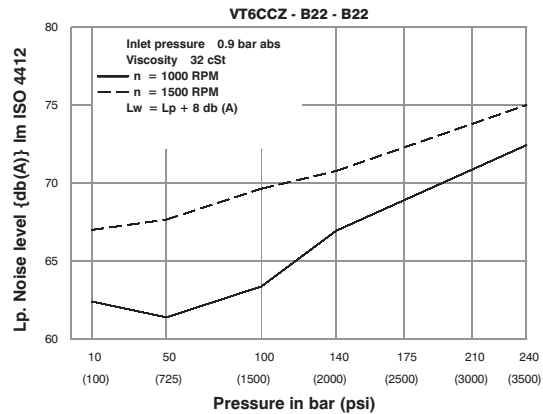

Double pump noise level is given with each section discharging at the pressure noted on the curve.

### HYDROMECHANICAL POWER LOSS (TYPICAL)

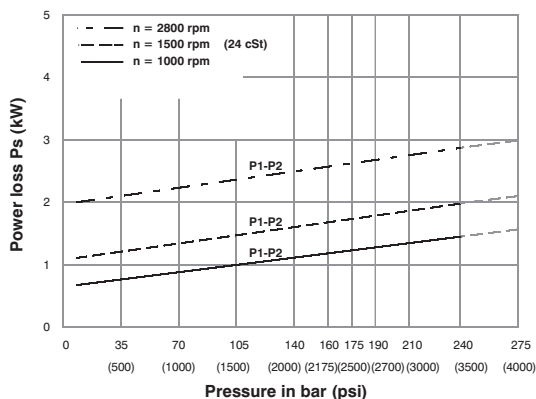

Total hydrodynamic power loss is the sum of each section at its operating conditions.

### PERMISSIBLE RADIAL LOAD

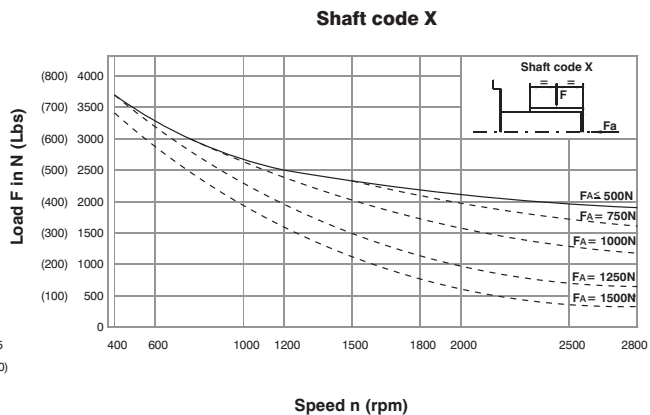

# HIGH PERFORMANCE VANE PUMP VT6CCZ



## PERMISSIBLE RADIAL LOAD

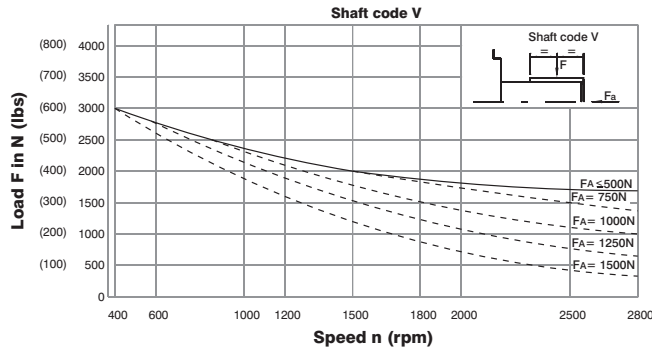

## PERMISSIBLE RADIAL LOAD

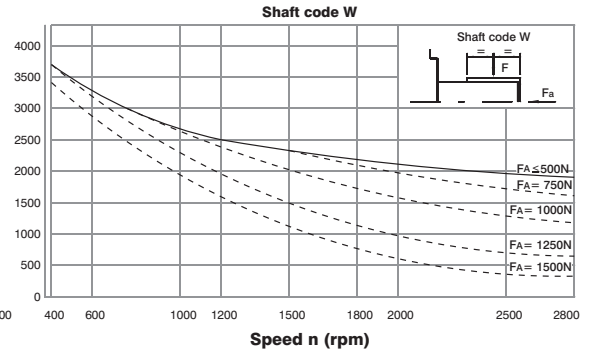

These curves permit to simultaneously check the maximum permissible radial and axial load on the shaft involved. Those load value are determined for 10000 hours bearing lifetime at operating under  $F_a$  and  $F$  given. To get information for a different lifetime the radial load corrected is.

If  $F_a$  is smaller than minimum axial force on the curves then

$$\text{Correct } F = \frac{F \text{ curve}}{\left(\frac{LH \text{ Required}}{10000}\right)^{\frac{1}{3.33}}} \quad LH = \text{Lifetime in hours}$$

If  $F_a$  is higher than minimum axial force then  $F$  radial load is :

$$\text{Correct } F = \frac{F \text{ curve}}{\left(\frac{LH \text{ Required}}{10000}\right)^{\frac{1}{3}}}$$

## Porting Diagrams

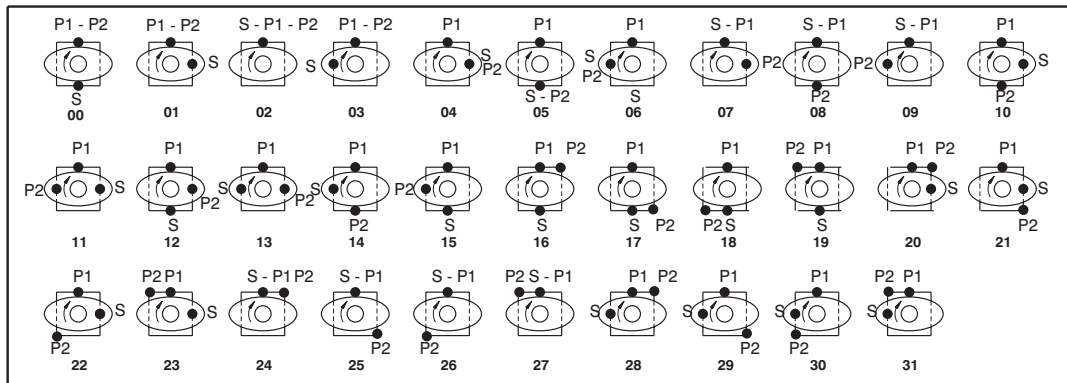

**VT6CC/VT6CCM -VT6CCSH-VT6DC/VT6DCM -VT6EC/VT6ECM-VT6CP-VT6GCC**

**VT7BB/VT7BBS-VT7QCC-VT7DB/VT7DBS-VT7QDC**

**VT7EB/VT7EBS-VT7QEC**

**VT67CB-VT67DB-VT67EB**

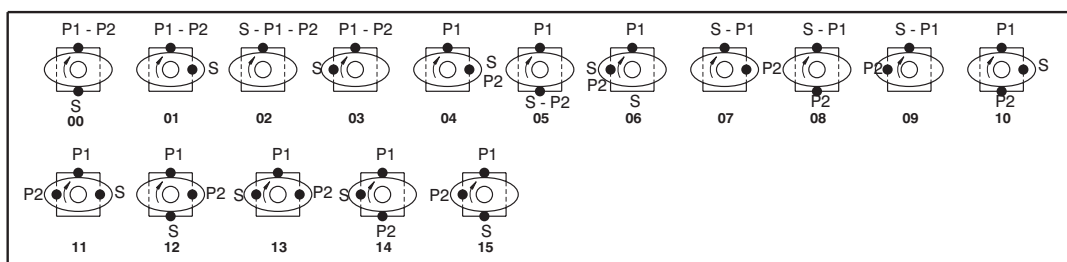

**VT6DDS-VT6ED/VT6EDM-VT6EES**

**VT7DD/VT7DDS-VT7ED/VT7EDS**

**VT7EE/VT7EES**

# HIGH PERFORMANCE VANE PUMP VT6CCZ

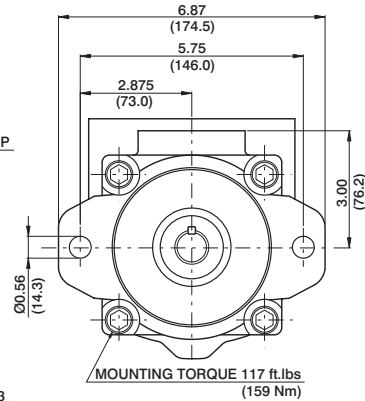
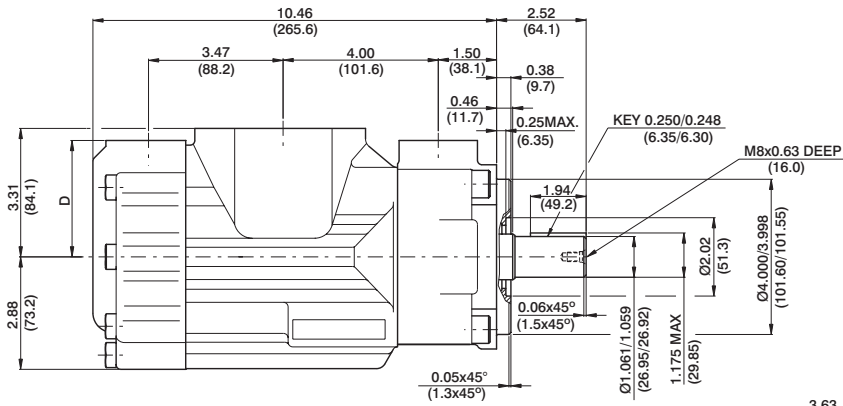
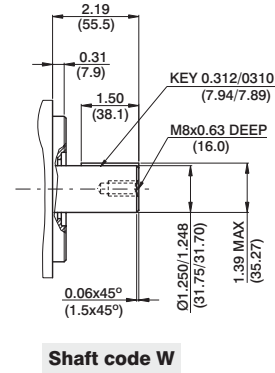
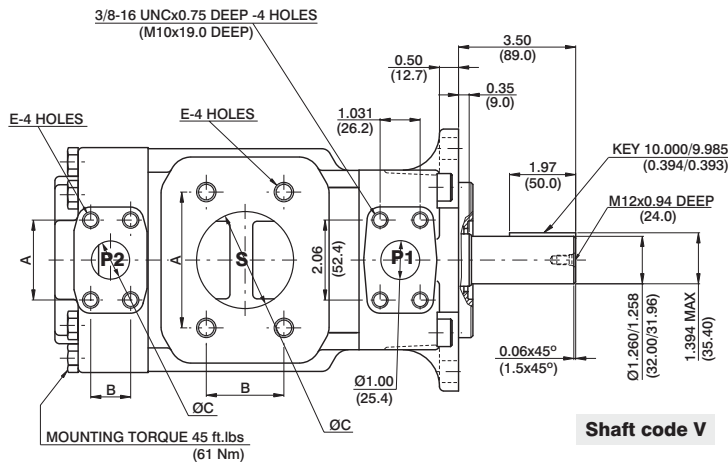

Shaft torque limits in <sup>2</sup> /rev x psi (ml/rev x bar)	
Shaft	Vp x p max. (P1 + P2)
X	22500 (25400)
V	28937 (32670)
W	28937 (32670)

PORT	A	B	C	D	E
S	4.19 (106.4)	2.44 (61.9)	3.00 (76.2)		5/8-11UNCx1.12 DEEP (M16 x 28.4 DEEP)
S	3.50 (88.9)	2.00 (50.8)	2.50 (63.5)		1/2-13UNCx0.94 DEEP (M12 x 24.0 DEEP)
P2	1.874 (47.6)	0.874 (22.2)	0.75 (19.0)	3.00 (76.2)	3/8-16UNCx0.75 DEEP (M10x19.0 DEEP)
P2	2.06 (52.4)	1.03 (26.2)	1.00 (25.4)	2.94 (74.7)	

## OPERATING CHARACTERISTICS - TYPICAL (24 cST) (Input power p (KW) for one cartridge only)

Pressure port	Series	Volumetric Displacement Vp		Flow q & n = 1500 rpm						Input power p & n = 1500 rpm					
				p = 0 bar (0 psi)		p = 140 bar (2000 psi)		p = 240 bar (3500 psi)		p = 7 bar (100 psi)		p = 140 bar (2000 psi)		p = 240 bar (3500 psi)	
		in <sup>3</sup> /rev	cm <sup>3</sup> /rev	gpm	lpm	gpm	lpm	gpm	lpm	hp	kw	hp	kw	hp	kw
P1 & P2	B03	0.66	10.8	4.29	16.2	2.83	10.7	--	--	1.74	1.3	7.11	5.3	--	--
	B05	1.05	17.2	6.83	25.8	5.37	20.3	4.17	15.8	1.88	1.4	10.06	7.5	16.36	12.2
	B06	1.30	21.3	8.44	31.9	7.01	26.5	5.82	22.0	2.01	1.5	11.94	8.9	19.71	14.7
	B08	1.61	26.4	10.48	39.6	9.02	34.1	7.83	29.6	2.15	1.6	14.35	10.7	22.93	17.7
	B10	2.08	34.1	13.52	51.1	12.08	45.7	10.89	41.2	2.28	1.7	18.64	13.4	29.90	22.3
	B12	2.26	37.1	14.71	55.6	13.28	50.2	12.08	45.7	2.28	1.7	19.31	14.4	32.32	24.1
	B14	2.81	46.0	18.25	69.0	16.79	63.5	15.60	59.0	2.55	1.9	23.60	17.6	39.56	29.5
	B15	3.08	50.5	20.00	75.6	18.62	70.4	17.46	66.0	2.68	2.0	25.61	19.1	42.91	32.0
	B17	3.56	58.3	23.12	87.4	21.69	82.0	20.50	77.5	2.82	2.1	29.37	21.9	49.48	36.9
	B20	3.89	63.8	25.32	95.7	23.86	90.2	22.67	85.7	2.95	2.2	31.92	23.8	53.91	40.2
	B22	4.29	70.3	27.88	105.4	26.45	100.0	25.26	95.5	3.08	2.3	35.00	26.1	59.14	44.1
	B25 <sup>1)</sup>	4.84	79.3	31.46	118.9	30.02	113.5	28.83	109.0	3.35	2.5	39.16	29.2	66.38	49.5
	B28 <sup>1)</sup>	5.42	88.8	35.24	133.2	33.78	127.7	32.93 <sup>2)</sup>	124.5 <sup>2)</sup>	3.75	2.8	43.85	32.7	65.04 <sup>2)</sup>	48.5 <sup>2)</sup>
	B31 <sup>1)</sup>	6.10	100.0	39.68	150.0	38.22	144.5	37.38 <sup>2)</sup>	141.3 <sup>2)</sup>	3.75	2.8	48.95	36.5	72.95 <sup>2)</sup>	54.4 <sup>2)</sup>

1) B25-B28-B31 = 2500 R.P.M. max.

2) B28-B31 = 210 bar (3000 psi) max. int.

-- Not to use because internal leakage greater than 50% theoretical flow.