

VT67EDB SERIES TRIPLE VANE PUMPS

High performance pumps for industrial use,
max pressure up to 320 bar.



HIGH PERFORMANCE VANE PUMP VT67EDB

VT67EDB - 062 - 035 - B10 - 1 R 00 - A 1 - P - 1 - *

Series-250 B4HW
ISO 3019-2 Mounting flange J744c

Cam ring for "P1"
Volumetric displacement cm³/rev (in³/rev)

042 = 132.3 (8.07)	062 = 196.7 (12.00)
045 = 142.4 (8.69)	066 = 213.3 (13.02)
050 = 158.5 (9.67)	072 = 227.1 (13.86)
052 = 164.8 (10.06)	085 = 269.8 (16.46)
057 = 180.7 (11.02)	

Cam ring for "P2"
Volumetric displacement cm³/rev (in³/rev)

*014/B14 = 47.6 (2.90)	035/B35 = 111.0 (6.77)
017/B17 = 58.2 (3.55)	038/B38 = 120.3 (7.34)
020/B20 = 66.0 (4.03)	042/B42 = 136.0 (8.30)
024/B24 = 79.5 (4.85)	045/B45 = 145.7 (8.89)
028/B28 = 89.7 (5.47)	050/B50 = 158.0 (9.64)
031/B31 = 98.3 (6.00)	061/B61 = 190.5 (11.62)

*0 - Uni - directional 'B' - Bi - directional

Cam ring for "P3"
Volumetric displacement cm³/rev (in³/rev)

B02 = 5.7 (0.35)	B09 = 28.0 (1.71)
B03 = 9.8 (0.60)	B10 = 31.8 (1.94)
B04 = 12.8 (0.78)	B11 = 34.9 (2.13)
B05 = 15.9 (0.97)	B12 = 40.9 (2.50)
B06 = 19.8 (1.21)	B14 = 45.1 (2.75)
B07 = 22.5 (1.37)	B15 = 50.0 (3.05)
B08 = 24.9 (1.52)	

Modifications

Mounting w/connection variables

4 bolts SAE flange
(J518c) Metric thread
1 = P3 = 3/4" SAE

Mounting (pump)

P = Pedestal mounting
F = Face mounting

Seal class

1 - S1 (for minreal oil)
4 - S4 (for fire resistant fluids)
5 - S5 (for mineral oil and fire resistant fluids)

Design letter

Porting combination (see page CI-1-4,5)

00 = Standard

Direction of rotation (view on the shaft)

R - Clockwise
L - Counter - clockwise

Type of Shaft

1 - Keyed (G45N-ISO 3019-2)



OPERATING CHARACTERISTICS - TYPICAL (24 cST) (Input power p (KW) for one cartridge only)

Pressure port	Series	Volumetric Displacement Vp		Flow q & n = 1800 rpm						Input power p & n = 1800 rpm						
				p = 0 bar (0 psi)		p = 140 bar (2000 psi)		p = 240 bar (3500 psi)		p = 7 bar (100 psi)		p = 140 bar (2000 psi)		p = 240 bar (3500 psi)		
		in ³ /rev	cm ³ /rev	gpm	lpm	gpm	lpm	gpm	lpm	hp	kw	hp	kw	hp	kw	
P1	042	8.07	132.3	62.92	237.8	60.37	228.2	58.52	221.2	8.09	6.03	78.44	58.49	133.80	99.78	
	045	8.69	142.4	67.72	256.0	65.17	246.3	63.32	239.4	8.37	6.24	84.04	62.67	143.60	107.08	
	050	9.67	158.5	75.38	285.0	72.83	275.3	70.98	268.3	8.82	6.58	92.97	69.30	159.24	118.7	
	052	10.06	164.8	78.37	296.2	75.82	286.3	73.97	279.6	8.99	6.70	96.47	71.94	165.36	121.31	
	057	11.02	180.7	71.70	325.3	69.07	261.1	80.63	304.8	9.40	7.00	114.30	85.14	172.10	128.30	
	062	12.00	196.7	93.54	353.6	90.99	344.0	89.14	337.0	9.88	7.36	114.17	84.00	196.34	146.41	
	066	13.02	213.3	101.44	383.4	98.89	373.8	97.04	366.8	10.34	7.71	123.38	92.01	212.46	158.43	
	072	13.86	227.1	108.00	408.2	105.45	400.0	103.60	391.6	10.72	8.00	131.04	97.72	225.86	168.42	
	085 ¹⁾	16.40	268.7	127.79	483.0	126.13 ²⁾	467.7 ³⁾	--	--	11.66	8.70	87.56 ²⁾	65.30 ²⁾	--	--	
	P2	014	2.90	47.6	22.64	85.0	20.46	77.4	18.8	71.1	4.02	2.99	29.31	21.85	49.34	36.79
017		3.55	58.2	23.1	87.3	20.6	78.0	18.99	71.8	3.35	2.5	29.77	22.2	49.62	37.0	
020		4.03	66.0	31.39	118.6	29.29	101.4	27.57	104.2	4.53	3.38	39.52	29.47	67.21	50.11	
024		4.85	79.5	37.81	142.8	35.63	134.6	33.99	128.5	4.91	3.66	47.02	35.06	80.32	59.89	
028		5.47	89.7	42.66	161.3	40.48	153.0	38.84	146.8	5.19	3.87	52.68	39.28	90.23	67.28	
031		6.00	98.3	46.75	176.7	44.57	168.5	42.93	162.3	5.43	4.09	57.45	42.84	98.58	73.51	
035		6.77	111.0	52.79	199.6	50.61	191.3	48.97	184.1	5.78	4.31	64.50	48.09	110.91	82.70	
038		7.34	120.3	57.21	216.3	55.03	208.1	53.39	201.8	6.04	4.50	69.66	51.94	111.94	83.47	
042 ¹⁾		8.30	136.0	64.68	244.5	62.50	236.3	60.86	230.1	6.47	4.83	78.37	58.44	135.19	100.81	
045 ¹⁾		8.89	145.7	69.29	261.9	67.11	253.7	65.47	247.5	6.74	5.02	83.75	62.45	144.61	107.83	
P3	050 ¹⁾	9.64	158.0	75.14	284.1	72.96	275.8	71.78 ³⁾	271.3 ³⁾	7.08	5.27	90.58	67.54	134.54 ³⁾	100.32 ³⁾	
	061 ¹⁾	11.62	190.5	75.6	285.8	73.54 ⁴⁾	278.0 ⁴⁾	--	--	7.37	5.50	97.49 ⁴⁾	72.69 ⁴⁾	--	--	
					p = 0 bar (0 psi)	p = 140 bar (2000 psi)	p = 300 bar (4350 psi)	p = 7 bar (100 psi)	p = 140 bar (2000 psi)	p = 300 bar (4350 psi)						
	B02	0.35	5.7	2.76	10.4	2.33	8.8	1.80	6.8	0.74	0.55	4.02	2.99	8.10	6.40	
	B03	0.60	9.8	4.66	17.6	4.23	15.9	3.70	14.0	0.85	0.63	6.24	4.65	12.93	10.25	
	B04	0.78	12.8	6.09	23.0	5.66	21.4	5.13	19.4	0.94	0.70	7.90	5.89	16.55	13.13	
	B05	0.97	15.9	7.56	28.6	7.13	26.9	6.60	25.0	1.02	0.76	9.62	7.17	20.29	16.12	
	B06	1.21	19.8	9.42	35.6	8.99	33.9	8.46	32.0	1.13	0.84	11.79	8.79	25.00	19.88	
	B07	1.37	22.5	10.70	40.4	10.27	38.8	9.74	36.8	1.20	0.89	13.29	9.91	28.26	22.47	
	B08	1.52	24.9	11.84	44.7	11.41	43.1	10.88	41.1	1.27	0.94	14.62	10.90	31.15	24.78	
B09	1.71	28.0	13.31	50.3	12.87	48.6	12.35	47.0	1.36	1.01	16.35	12.19	34.92	27.77		
B10	1.94	31.8	15.12	57.2	14.69	55.5	14.16	53.5	1.46	1.11	18.45	13.75	39.48	31.42		
B11	2.13	34.9	16.64	62.9	16.19	61.2	15.68	59.3	1.55	1.15	20.17	15.04	43.22	32.22		
B12	2.50	40.9	19.50	73.7	19.07	72.1	18.54	70.1	1.72	1.28	23.55	17.56	50.58	37.71		
B14	2.75	45.1	21.40	80.8	20.95	79.2	20.44	77.0	1.83	1.36	25.80	19.23	55.48	41.37		
B15	3.05	50.0	23.78	89.8	23.35	88.3	22.88 ⁵⁾	86.5 ⁵⁾	1.97	1.47	28.55	21.28	57.35 ⁵⁾	42.76 ⁵⁾		

1) 042-045-050-061-085 = 2000 RPM max.

2) 085 = 75 bar (1087 psi) cont. 085 = 90 bar (1300 psi) max. int.

3) 050=210 bar (3000 psi) max.

4) 061 = 120 bar (1740 psi) max. int. 061 = 80 bar (1160 psi) cont.

5) B15 = 280 bar (4060 psi) max. int.

HIGH PERFORMANCE VANE PUMP VT67EDB

INTERNAL LEAKAGE (TYPICAL)

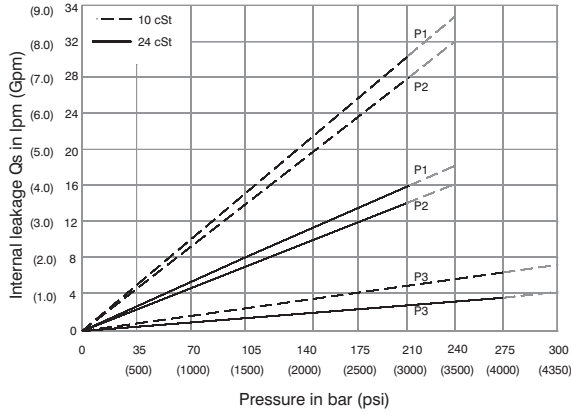

Do not operate pump more than 5 seconds at any speed or viscosity if internal leakage is more than 50% of theoretical flow. Total leakage is the sum of each section loss at its operating conditions.

NOISE LEVEL (TYPICAL)

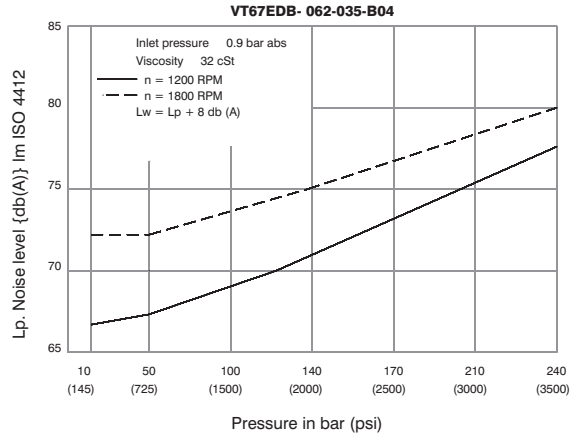

Triple pump noise level is given with each section discharging at the pressure noted on the curve.

HYDROMECHANICAL POWER LOSS (TYPICAL)

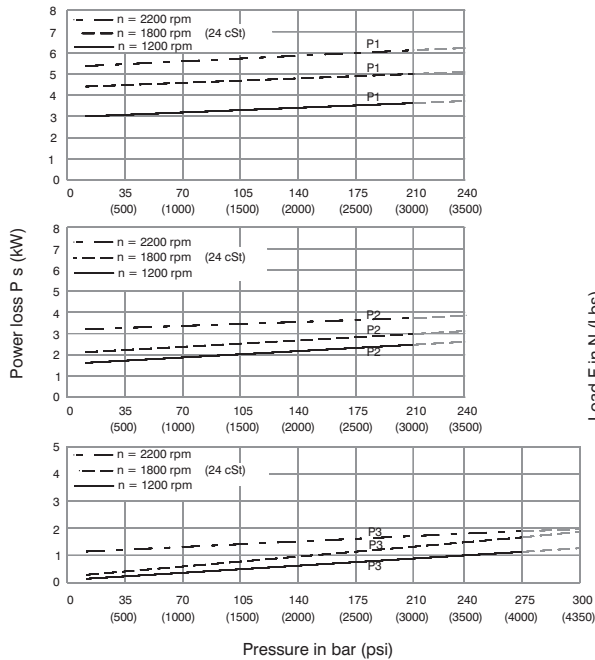

Total hydromechanical power loss is the sum of each section at its operating conditions

PERMISSIBLE RADIAL LOAD

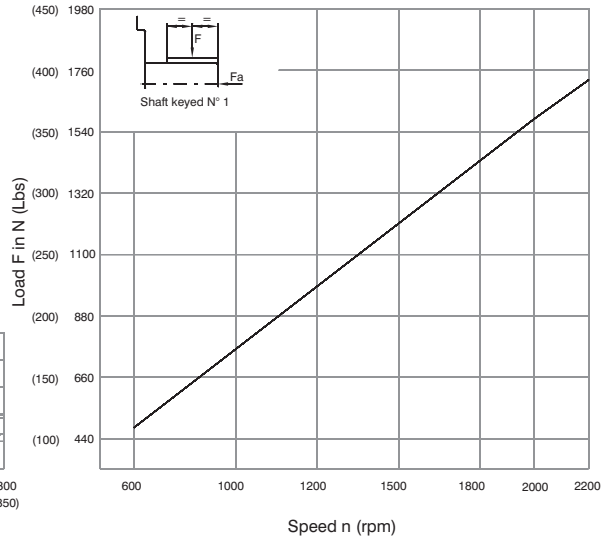

Maximum axial load permissible $F_a=2000$ N (449 Lbs)

HIGH PERFORMANCE VANE PUMP VT67EDB

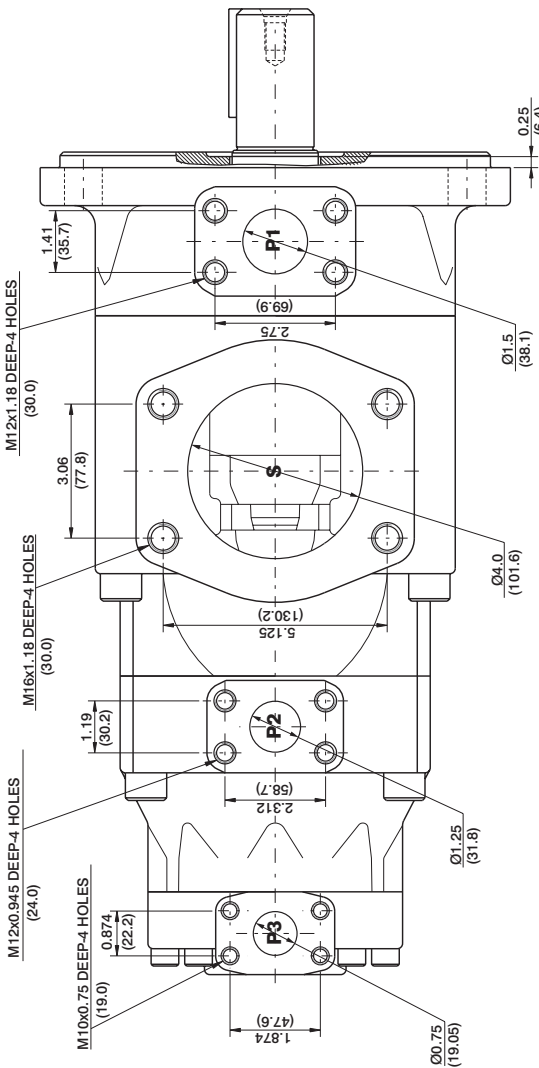

Shaft torque limits in ³ /rev x psi (mi/rev x bar)	
Shaft	Vp x p max. (P1+P2+P3)
1	101506 (114715)

