

VT6EDC SERIES TRIPLE VANE PUMPS

High performance pumps for industrial use,
max pressure up to 275 bar.



HIGH PERFORMANCE VANE PUMP VT6EDC

VT6EDC - 062 - 035 - 017 - 1 R 00 - C 1 - P - 0 - *

Series

Cam ring for "P1"
 Volumetric displacement cm³/rev (in³/rev)
 042 = 132.3 (8.07) 062 = 196.7 (12.00)
 045 = 142.4 (8.69) 066 = 213.3 (13.02)
 050 = 158.5 (9.67) 072 = 227.1 (13.86)
 052 = 164.8 (10.06) 085 = 269.8 (16.46)
 057 = 180.7 (11.02)

Cam ring for "P2"
 Volumetric displacement cm³/rev (in³/rev)
 *014/B14 = 47.6 (2.90) 035/B35 = 111.0 (6.77)
 017/B17 = 58.2 (3.55) 038/B38 = 120.3 (7.34)
 020/B20 = 66.0 (4.03) 042/B42 = 136.0 (8.30)
 024/B24 = 79.5 (4.85) 045/B45 = 145.7 (8.89)
 028/B28 = 89.7 (5.47) 050/B50 = 158.0 (9.64)
 031/B31 = 98.3 (6.00) 061/B61 = 190.5 (11.62)

*0' - Uni - directional 'B' - Bi - directional

Cam ring for "P3"
 Volumetric displacement cm³/rev (in³/rev)
 *003/B03 = 10.8 (0.66) 015/B15 = 50.5 (3.08)
 005/B05 = 17.2 (1.05) 017/B17 = 58.3 (3.56)
 006/B06 = 21.3 (1.30) 020/B20 = 63.8 (3.89)
 008/B08 = 26.4 (1.61) 022/B22 = 70.3 (4.29)
 010/B10 = 34.1 (2.08) 025/B25 = 79.3 (4.84)
 012/B12 = 37.1 (2.26) 028/B28 = 88.8 (5.42)
 014/B14 = 46.0 (2.81) 031/B31 = 100.0 (6.10)

*0' - Uni - directional 'B' - Bi - directional

Modifications
Mounting w/connection variables
 0 = P3 = 1" SAE
 1 = P3 = 3/4" SAE

Mounting (pump)
 P= Pedestal mounting
 F= Face mounting

Seal class
 1 - S1 (for mineral oil)
 4 - S4 (for fire resistant fluids)
 5 - S5 (for mineral oil and fire resistant fluids)

Design letter

Porting combination (see page CI-1-4,5)
 00 = Standard

Direction of rotation (view on shaft end)
 R - Clockwise
 L - Counter - clockwise

Type of Shaft
 1 - Keyed (G45N-ISO 3019-2)



OPERATING CHARACTERISTICS - TYPICAL (24 cST) (Input power p (KW) for one cartridge only)

Pressure port	Series	Volumetric Displacement Vp		Flow q & n = 1500 rpm						Input power p & n = 1500 rpm					
		in ³ /rev	cm ³ /rev	p = 0 bar (0 psi)	p = 140 bar (2000 psi)	p = 140 bar (2000 psi)	p = 240 bar (3500 psi)	p = 240 bar (3500 psi)	p = 7 bar (100 psi)	p = 140 bar (2000 psi)	p = 140 bar (2000 psi)	p = 240 bar (3500 psi)	p = 240 bar (3500 psi)		
				gpm	lpm	gpm	lpm	gpm	lpm	hp	kw	hp	kw	hp	kw
P1	042	8.07	132.3	52.50	198.5	49.87	188.5	47.96	181.3	6.97	5.2	66.25	49.4	110.77	82.6
	045	8.70	142.4	56.51	213.6	53.86	203.6	51.98	196.5	7.24	5.4	70.94	52.9	118.95	88.7
	050	9.67	158.5	62.88	237.7	60.24	227.7	58.36	220.6	7.64	5.7	78.45	58.5	131.82	98.3
	052	10.00	164.8	65.40	247.2	62.75	237.2	60.87	230.1	7.78	5.8	81.53	60.8	136.92	102.1
	057	11.02	180.7	71.71	271.1	69.07	261.1	67.19	254.0	8.18	6.1	89.04	66.4	143.35	106.9
	062	12.00	196.7	78.04	295.0	75.40	285.0	73.52	277.9	8.58	6.4	96.42	71.9	162.67	121.3
	066	13.00	213.3	84.63	319.9	81.98	309.9	80.11	302.8	8.98	6.7	104.20	77.7	175.94	131.2
	072	13.86	227.1	90.11	340.6	87.46	330.6	85.58	323.5	9.25	6.9	110.77	82.6	187.07	139.5
	085 ¹⁾	16.40	269.8	107.00	404.7	105.21 ²⁾	397.7 ²⁾	--	--	9.78	7.3	87.56 ²⁾	65.3 ²⁾	--	--
P2	014	2.90	47.6	18.88	71.4	16.42	62.1	14.78	55.9	3.08	2.3	24.81	18.5	41.03	30.6
	017	3.55	58.2	23.1	87.3	20.6	78.0	18.99	71.8	3.35	2.5	29.77	22.2	49.62	37.0
	020	4.00	66.0	26.19	99.0	23.73	89.7	22.08	83.5	3.75	2.8	33.39	24.9	55.92	41.7
	024	4.80	79.5	31.56	119.3	29.10	110.0	27.46	103.8	4.02	3.0	39.69	29.6	66.78	49.8
	028	5.50	89.7	35.58	134.5	33.12	125.2	31.48	119.0	4.29	3.2	44.52	33.2	74.96	55.9
	031	6.00	98.3	39.00	147.5	36.53	138.1	34.89	131.9	4.42	3.3	48.54	36.2	81.80	61.0
	035	6.80	111.0	44.04	166.5	41.58	157.2	39.94	151.0	4.69	3.5	54.58	40.7	92.13	68.7
	038	7.30	120.3	47.72	180.4	45.26	171.1	43.62	164.9	4.96	3.7	58.87	43.9	99.64	74.3
	042	8.30	136.0	53.96	204.0	51.50	194.7	49.86	188.5	5.36	4.0	66.25	49.4	112.24	83.7
	045	8.89	145.7	57.80	218.5	55.34	209.2	53.70	203.0	5.50	4.1	70.81	52.8	120.02	89.5
	050	9.64	158.0	62.69	237.0	60.23	227.7	59.25 ³⁾	224.0 ³⁾	5.90	4.4	76.44	57.0	113.98 ³⁾	85.0 ³⁾
	061	11.62	190.5	76.25	285.7	73.54 ⁴⁾	278.0 ⁴⁾	--	--	6.16	4.6	81.26 ⁴⁾	60.6 ⁴⁾	--	--
	P3	003	0.66	10.8	4.29	16.2	2.96	11.2	2.04	7.7	1.74	1.3	7.11	5.3	11.22
005		1.05	17.2	6.83	25.8	5.50	20.8	4.57	17.3	1.88	1.4	10.06	7.5	16.36	12.2
006		1.30	21.3	8.44	31.9	7.11	26.9	6.19	23.4	2.01	1.5	11.94	8.9	19.71	14.7
008		1.61	26.4	10.48	39.6	9.15	34.6	8.22	31.1	2.15	1.6	14.35	10.7	22.93	17.7
010		2.08	34.1	13.52	51.1	12.19	46.1	11.26	42.6	2.28	1.7	18.64	13.4	29.90	22.3
012		2.26	37.1	14.71	55.6	13.36	50.6	12.46	47.1	2.28	1.7	19.31	14.4	32.32	24.1
014		2.81	46.0	18.25	69.0	16.93	64.0	16.00	60.5	2.55	1.9	23.60	17.6	39.56	29.5
015		3.08	50.5	20.00	75.6	18.73	73.2	19.02	67.5	2.68	2.0	25.61	19.1	42.91	32.0
017		3.56	58.3	23.12	87.4	21.79	82.4	20.87	78.9	2.82	2.1	29.37	21.9	49.48	36.9
020		3.89	63.8	25.32	95.7	23.99	90.7	23.07	87.2	2.95	2.2	31.92	23.8	53.91	40.2
022		4.29	70.3	27.88	105.4	26.56	100.4	25.63	96.9	3.08	2.3	35.00	26.1	59.14	44.1
025		4.84	79.3	31.46	118.9	30.13	113.9	29.21	110.4	3.35	2.5	39.16	29.2	66.38	49.5
028		5.42	88.8	35.24	133.2	33.92	128.2	33.28 ⁴⁾	125.8 ⁴⁾	3.75	2.8	43.85	32.7	65.04 ⁴⁾	48.5 ⁴⁾
031		6.10	100.0	39.68	150.0	38.35	145.0	37.72 ⁴⁾	142.6 ⁴⁾	3.75	2.8	48.95	36.5	72.95 ⁴⁾	54.4 ⁴⁾

1) 085 = 2000 RPM max.

2) 085 = 75 bar (1100 psi) cont. 085 = 90 bar (1300 psi) max. int.

3) 028-031-050=210 bar (3000 psi) max.

4) 061 = 120 bar(1740 psi) max. int, 061 = 80 bar (1160 psi) cont.

HIGH PERFORMANCE VANE PUMP VT6EDC

INTERNAL LEAKAGE (TYPICAL)

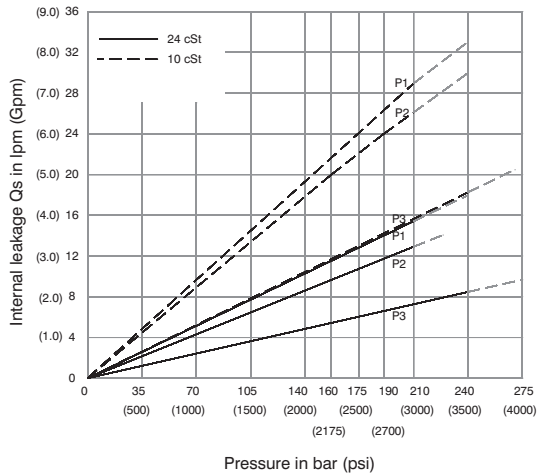

Total leakage is the sum of each section loss at its operating conditions.

NOISE LEVEL (TYPICAL)

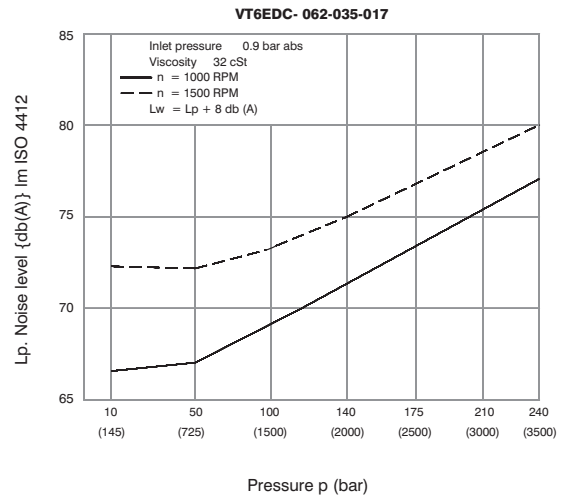

Triple pump noise level is given with each section discharging at the pressure noted on the curve.

HYDROMECHANICAL POWER LOSS (TYPICAL)

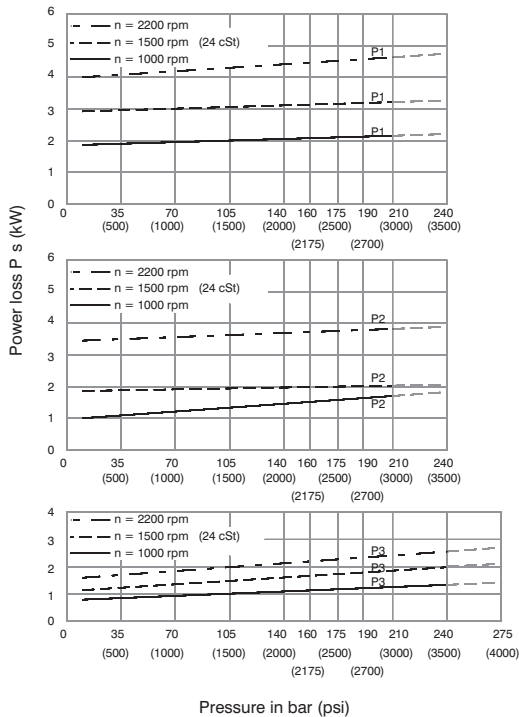

Total hydromechanical power loss is the sum of each section at its operating conditions

PERMISSIBLE RADIAL LOAD

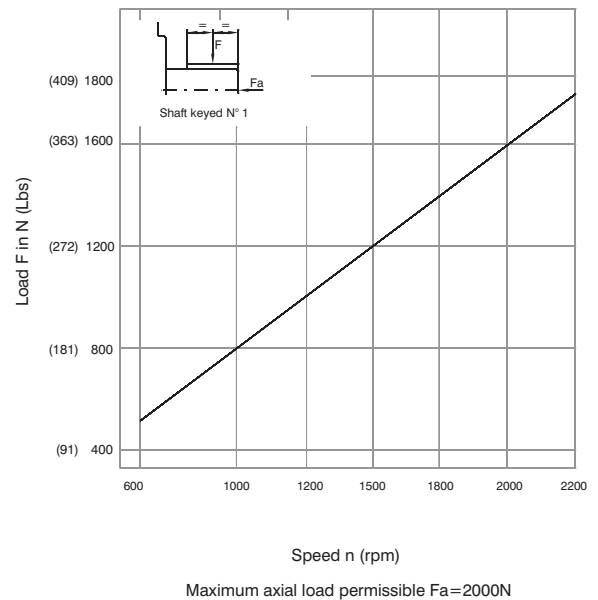

Maximum axial load permissible $F_a=2000N$

HIGH PERFORMANCE VANE PUMP VT6EDC

PORT CODE	A	B	C
0	2.06 (52.4)	1.03 (26.2)	1.00 (25.4)
P3	1.874 (47.6)	0.874 (22.2)	0.75 (19.05)

Shaft torque limits in ³ /rev x psi (ml/rev x bar)	
Shaft	Vp x D max. (P1+P2+P3)
1	101506 (114715)

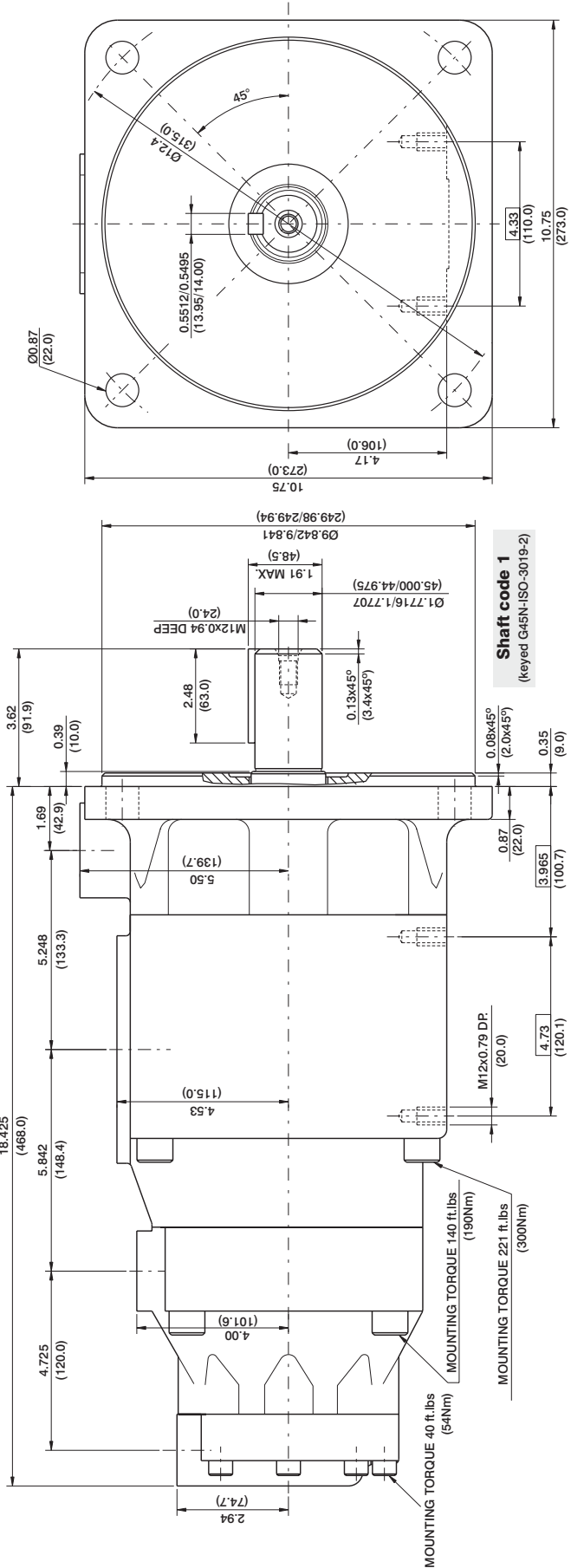
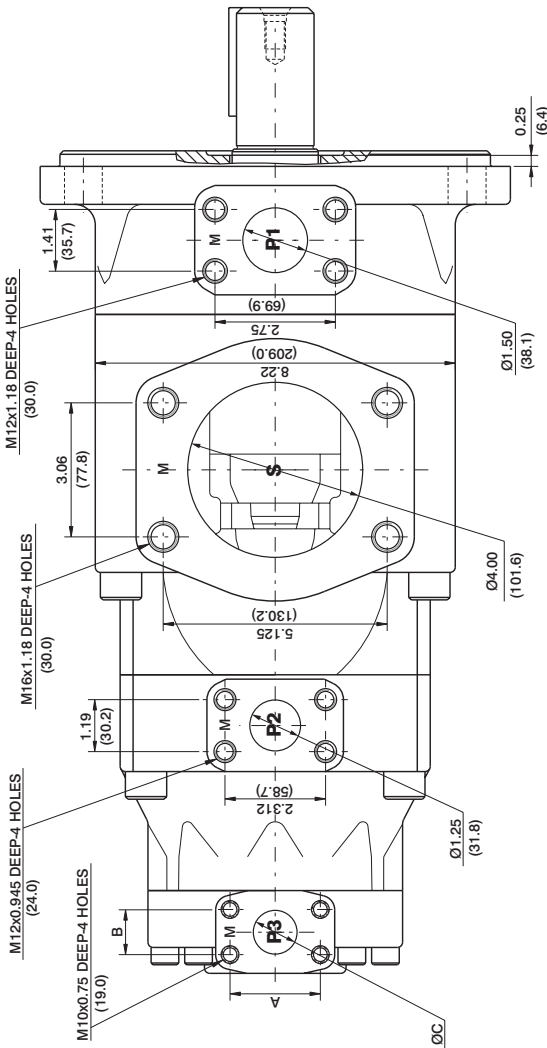

Shaft code 1
(keyed G45N-ISO-3019-2)

MOUNTING TORQUE 40 ft.lbs (54Nm)
MOUNTING TORQUE 140 ft.lbs (190Nm)
MOUNTING TORQUE 221 ft.lbs (300Nm)